

BATTERY RECEPTACLE - SERVICING

1. General

- A. It is recommended the airplane be secured in an area free of contamination from sand, dust or other environmental conditions that may contribute to improper lubrication practices.

2. Servicing

- A. Servicing Procedures (Refer to Figure 301).
 - (1) Open right engine cowling to gain access to battery and receptacle. Refer to Chapter 71, Engine Cowling and Nosecap - Maintenance Practices.
 - (2) Lubricate fasteners. Refer to Figure 301.
 - (3) Close right engine cowling. Refer to Chapter 71, Engine Cowling and Nosecap - Maintenance Practices.

Figure 301 : Sheet 1 : Battery Receptacle Lubrication

A22868

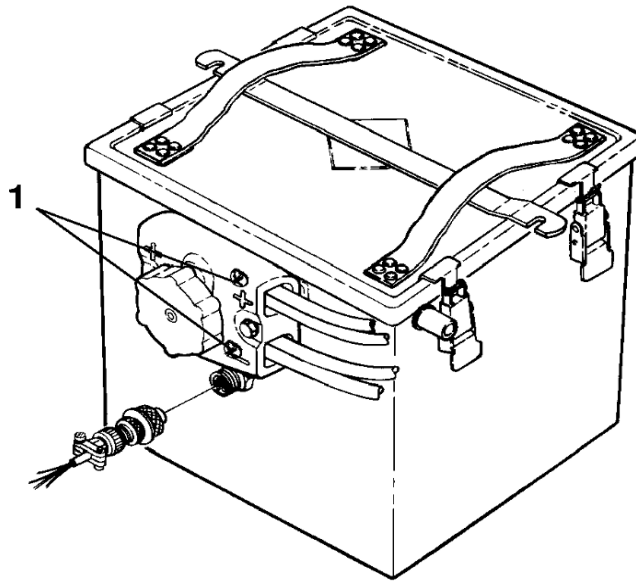

ITEM NUMBER	ITEM DESCRIPTION	LUBE TYPE	APPLICATION
1	FASTENERS	PL	HAND

PL - GREASE, PETROLATUM - VV-P-236

2614M2041